

8 Channels, Low Cost, Extended data recording onto a CF memory card.

**Recorder comes ready to use and is easy to operate.**

## Field Recording Unit

# es8



Approx. 150W×100D×40H mm

### Recorder Features Include:

- Low cost data recorder for vibration measurement and an 8 channel AD converter with a USB interface for laboratory use.
- Supported CF Card recording data formats are CSV, and TAFFmat (TEAC standard format consisting with a text header file and a binary data file).
- In addition to the manual operations such as Start or Stop, a various automatic measurement modes are also included such as; Level Trigger (Edge detection), Window Trigger, Pre/Post Trigger, and interval recording.
- With a built-in comparator output, the recorder can be used to monitor usage by generating an external alarm.
- Operates within the wide range of operating temperatures,  $-10^{\circ}\text{C} \sim 50^{\circ}\text{C}$ .

With an included accessory program, esNavi, you can configure to record onto a PC and monitor.



The overlay display is also available in the wave monitor.

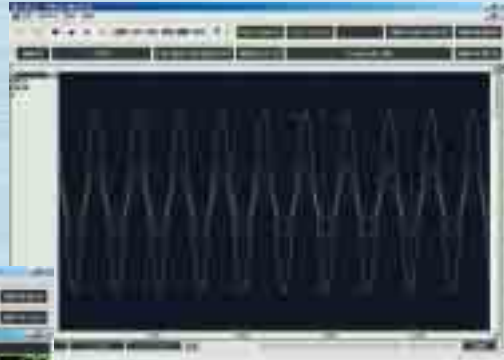

Combine the digital panel and the bar meter for monitoring.



The recorded TAFFmat file can be displayed by the wave display program. Separate purchase required.



The **es8 recorder** uses a Compact Flash memory card for recording. A stand-alone operation with the LCD and the key allows you to set, monitor, and record.

By connecting to a PC with a built-in USB interface, you can perform the wave monitor and the recording control. While simultaneously sampling on all channels, using the 16 bits A/D converter individually equipped in each channel, approximately four hours of continuous recording can be done with an internal dry cell battery. An external battery will extend recording time.

The sampling frequency ranges are 5kHz~1/60Hz. Combining with various types of sensor amplifiers, a wide range of measurement is possible such as; earthquake, natural phenomenon and structural vibration, mechanical vibration measurement of the strain measurement, and bio-signal measurement.

Exterior Drawing  
(External View)

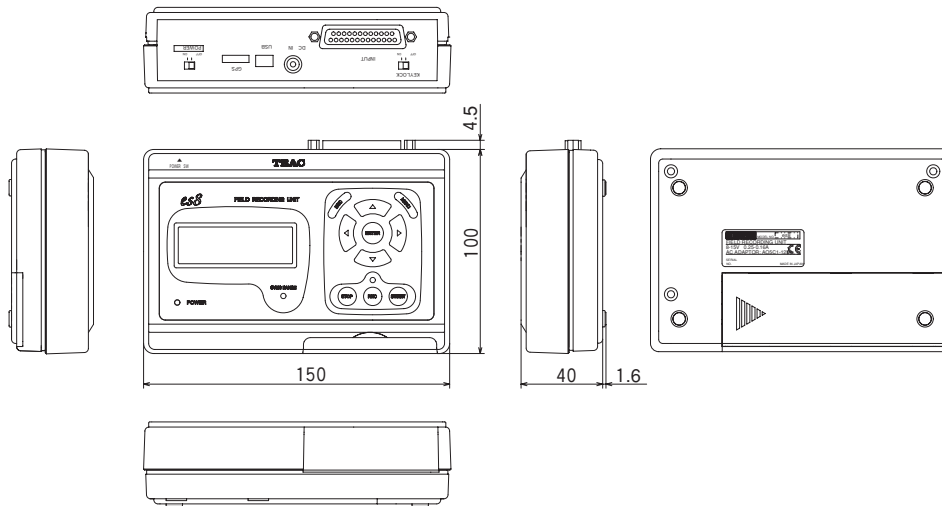

Specification

Number of Channels	8 channels. Individually ON/OFF selectable.
A/D Converter	16 bits successive approximation type. All channels simultaneously sampled (input filter not included)
Input Range/Type	$\pm 2, 5$ and $10V$ / unbalance Impedance: $1M\Omega$
Sampling Frequency	5KHz~1/60Hz (same sample frequency applied to all channels) (5K, 2K, 1K, 500, 200, 100, 50, 20, 10, 5, 2, 1, 1/2, 1/5, 1/10, 1/30, 1/60Hz)
Record Mode	Manual, Interval, Level Trigger (Edge/Window), External Trigger, Pre/Post Trigger
Comparator Output	One relay contact (normally open), Relay rating 40V 0.25A Manual/Level/Window (Trigger condition set separately from recording setting) Operation delay from the condition met: less than $300\mu\text{sec}$
Display	20 characters x 4 lines Character type LCD with backlight
Operation Key	REC, STANDBY, STOP, MENU, ENTER, ESC, UP, DOWN, RIGHT, LEFT
Record Media	Compact Flash (FAT16) Maximum 2GB
Data Format	Text CSV format or binary TAFFmat format selectable. The maximum sampling frequency is 50Hz for the CSV format.
PC Connection	USB 2.0 Full speed only. * USB Bus power operation is not available.
Clock Calibration	30 second adjustment
Operating Temperature and Humidity	$-10^{\circ}\text{C}\sim 50^{\circ}\text{C}$ (In use under low temperature, LCD may dew) $10\%\sim 85\%$ (non condensing)
Power Supply	Internal : AA type Nickel Metal-Hydride or 4 Alkaline batteries External: 8-15V DC 12V Please use the capacity of more than 0.2A for the DC operation, or the accessory AC adaptor.
External Dimension	Approx. $150W \times 100D \times 40H$ mm
Weight	Approx. 400g (internal batteries not included)
Accessories	User Manual, AC adaptor, D-sub 25pin connector, Navi software (for real-time display and control), AA Type dry cell batteries.
Safety Standard	VCCI Class A
Option	Input cable (D-sub 25 pin —BNC $\times 8$ ) Terminal box



**Caution**

Please read the manual prior to use of the product for proper and safe operation.

※ Exact product specifications and exterior appearance are subject to change without notice. (January, 2005)  
※ The company name and the product name are registered trademarks.

Contact Information

**TEAC CORPORATION**  
Business Solutions Company

3-7-3 Naka-cho, Musashino-shi, Tokyo 180-8550, Japan  
Phone: +81-422-52-5014 Fax: +81-422-52-1990 <http://www.tic.teac.co.jp/>